

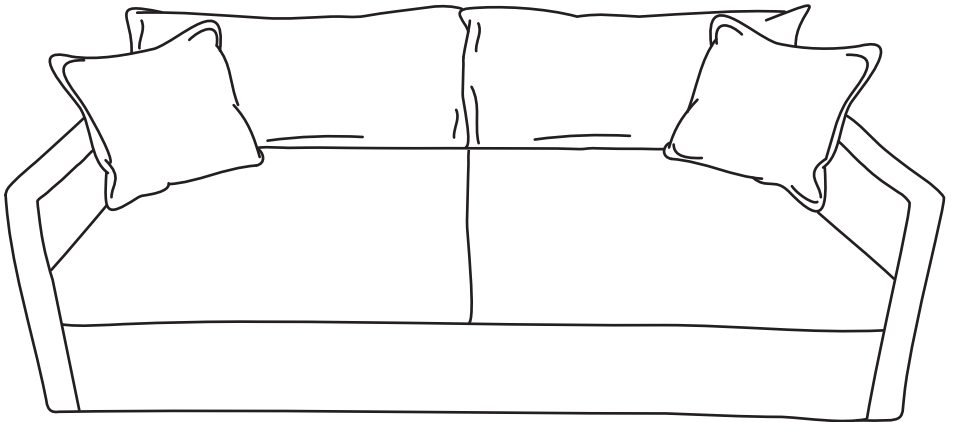

Caledonia Slip Cover Sofas

Installation & Washing Instructions



For your safety

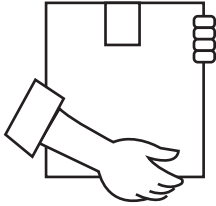

Lift, don't drag. This protects your floor and product.



Check the assembly guide for required components.



Assembly requires 2 people. It's always easier with a friend.

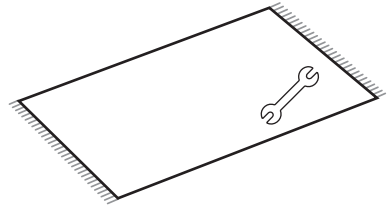

Assemble the product on a soft surface to protect the covers and frame.

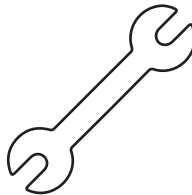

Avoid loose screws. Tighten fixtures every few months.

Components

Before you get started, check that you have all the components below. If anything is missing, contact the store where you made the purchase and a team member will arrange to have the missing component sent to you.

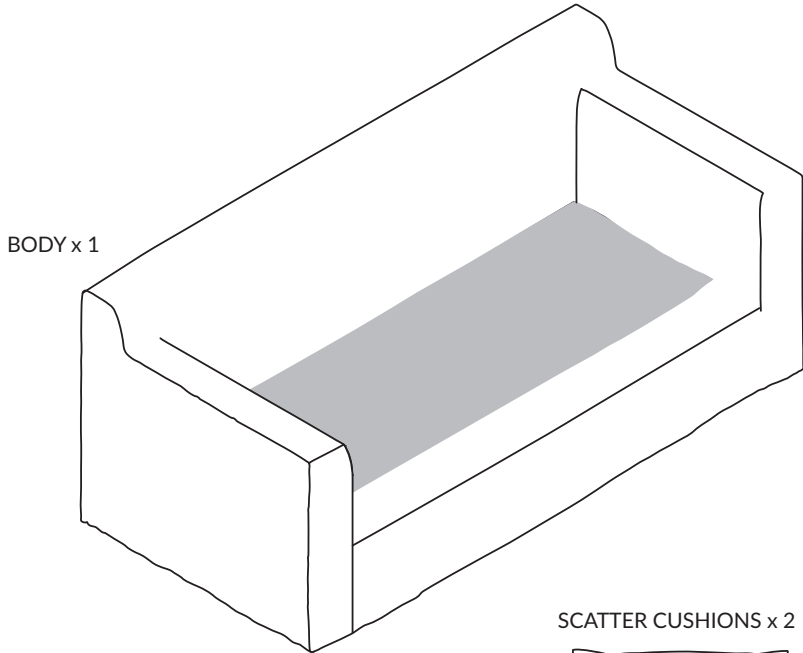

BODY x 1

SCATTER CUSHIONS x 2

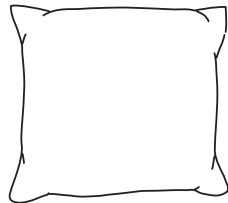

BASE CUSHIONS x 2

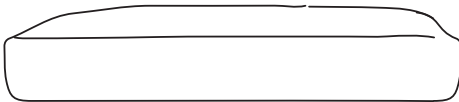

BACK CUSHIONS x 2

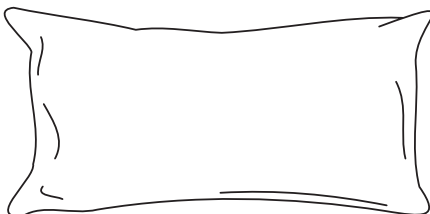

LEGS x 4



Assembly

Step 1

Turn the sofa so that the base faces you. Unzip the base fabric and remove the legs from inside. Zip the base fabric back up again.

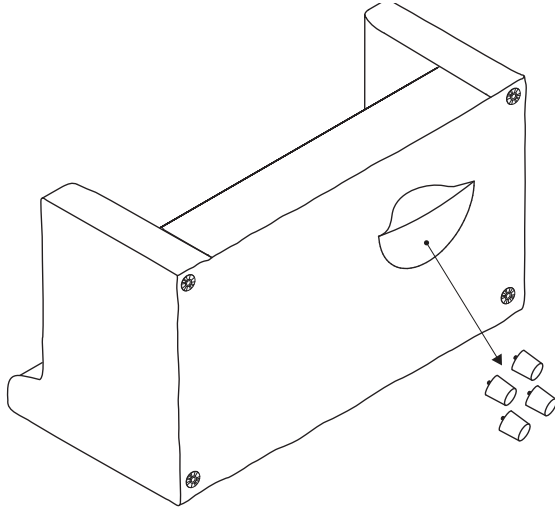

Step 2

Don't over-tighten the legs. Over-tightening will result in stripped screw threads.

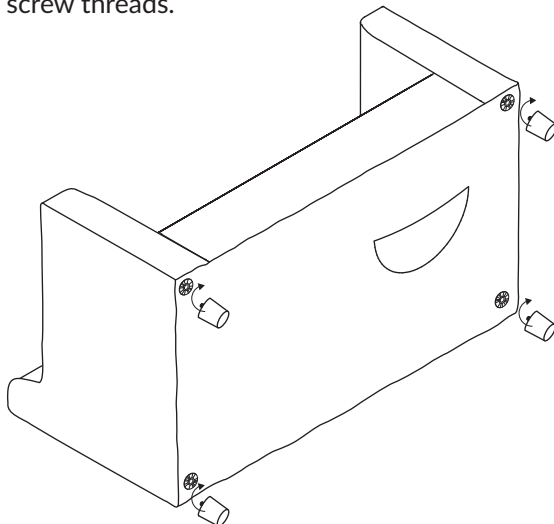

Step 3 Lift the sofa off the floor, turn it upright and position in its desired location.

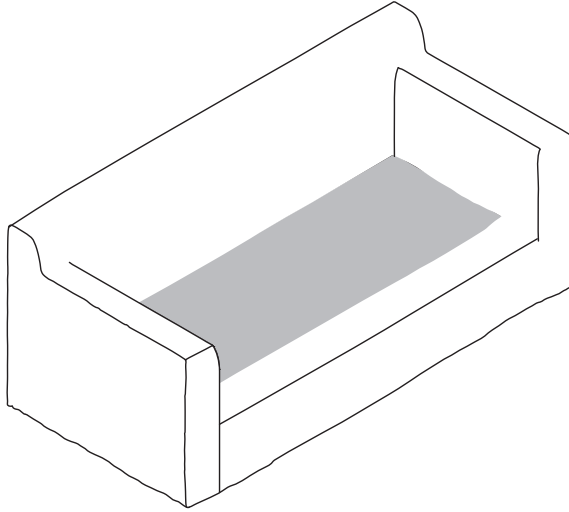

Slip cover assembly

For best results, two people should work together to remove and replace sofa covers. Don't over-stretch the cover at one end. Place covers on the same sections at the same time. Be careful not to tug away from the other person as it can cause the seams to pull.

Avoid opening the box with a knife as it may damage the slip covers.

Keep your installation and washing instructions in a safe place for future reference.

Step 1 Fit one corner onto the backrest.

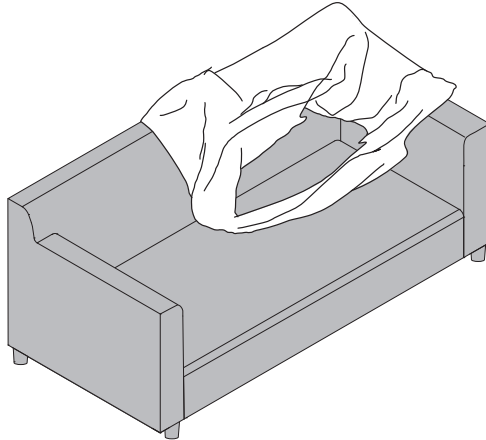

Step 2 Fit the other corner onto the backrest.

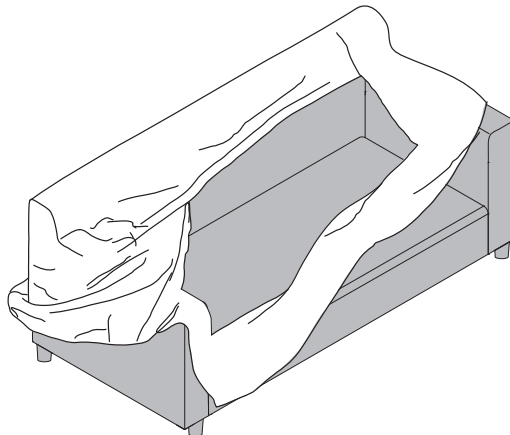

Step 3 Carefully dress both armrests with the cover.

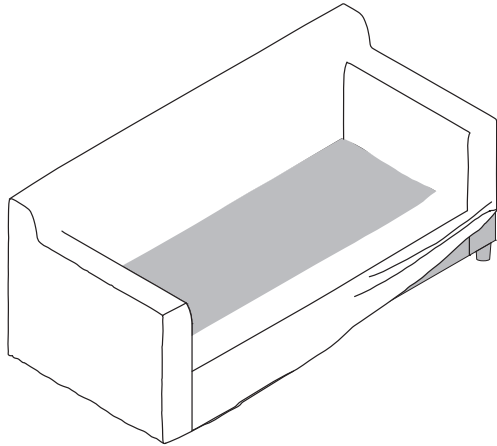

Step 4 Fix all four corners of the seat.

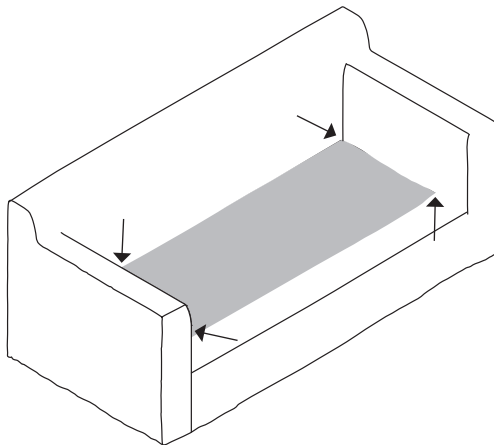

Step 5

Unzip the cushion covers and fold over the seat cushions. Make sure the corners of each cushion fit snugly. Use two people to close the zipper: one to hold the cushion fabric together while the other slowly zips up the cover. Make sure the foam and cover do not get caught in the zipper.

Step 6

Run your fingers along the edges to make sure the Velcro straps are attached neatly.

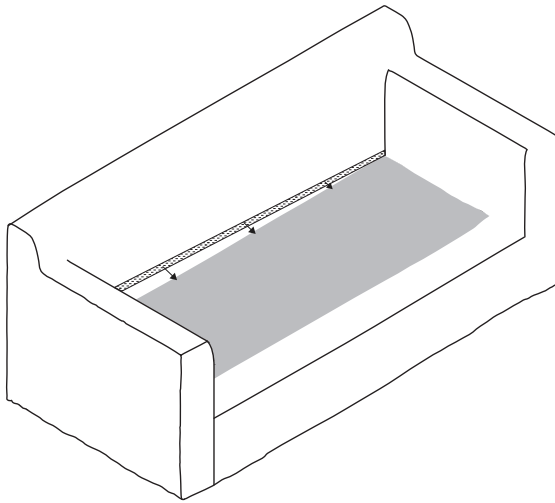

Slip Cover Removal

Step 1

Lift up the cover from one corner. Reverse the *Slip Cover Assembly* instructions.

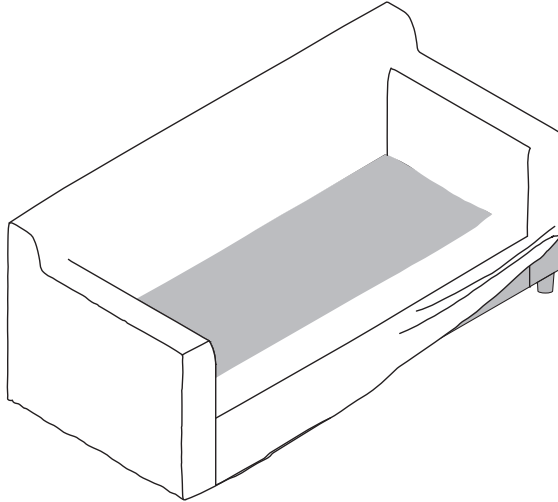

Step 2

Detach the Velcro straps along the bottom edges

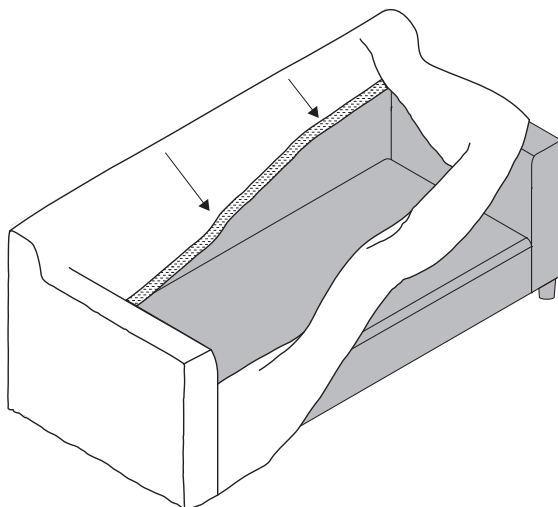

Step 3

Lift up the cover on the opposite corner.

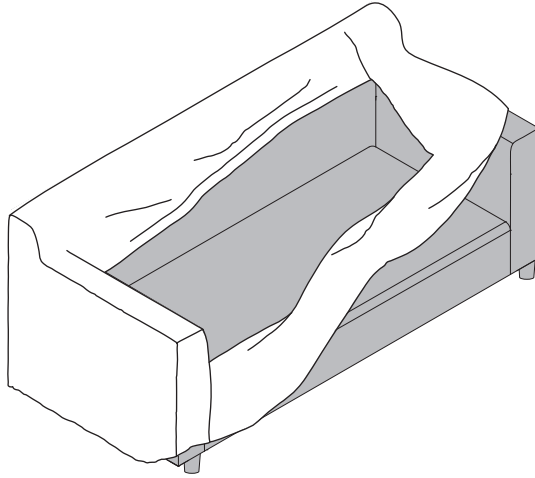

Step 4

Carefully remove the slipcover from the sofa.

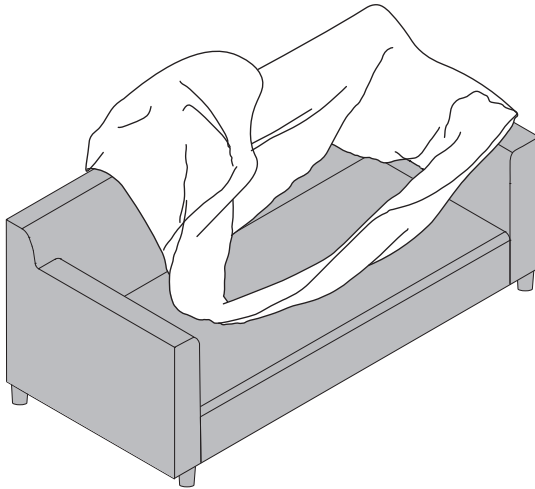

Step 5

When removing a cushion cover, slowly unzip and pull the sides of the cover down together. Don't remove the cover unless the zipper is completely undone.

Warning

1. The maximum weight limit for this sofa is 200 kg. Please **DO NOT** exceed the weight limit.

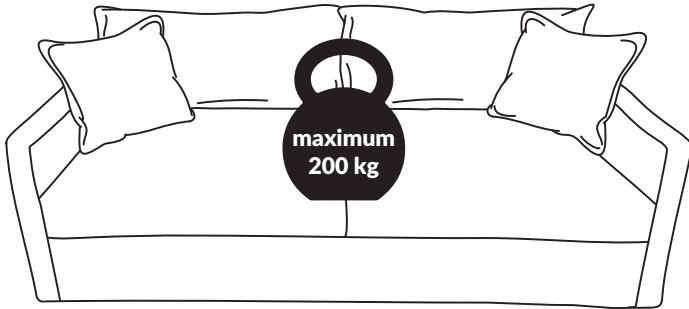

2. **DO NOT** sit on the armrests.

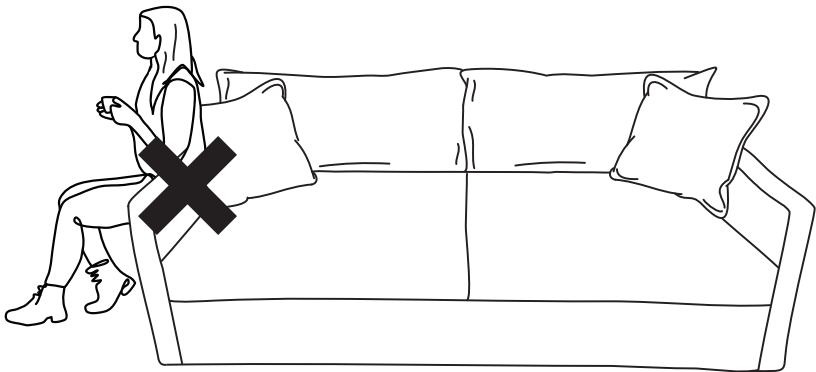

Fabric specifications

Fabric	100% Polyester
Classified as	Heavy Domestic Use
Flame Retardant	EN1021/1 and EN 1021/2 – European standards, BS 5852 UK Standards, Ca Tb 117-2013 USA Standard
Low seam slippage	Warp & Shrinkage 1–5 mm accepted
Low pilling	Pilling may occur depending on reactions with other fabrics (refer to Important Points on page 15)
This fabric is a classic flat woven textile with a semblance of linen. Excellent functional performance with an understated comfortable look.	

OEKO-TEX®
CONFIDENCE IN TEXTILES
STANDARD 100



texstyle.dk

Caledonia Sofa Warranty

- Sofa frame – 2 years.
- Fabric –1 year. The fabric will be tested to ensure the customer followed the washing instructions correctly.
- All warranty service calls or transport for inspection of a manufacturing fault is at the customer's expense.

Guardmans Fabric Protection

- The warranties cover the Caledonia sofa with slip washable covers for 5 years if washing instructions are adhered to correctly and Guardsman's recommendations are followed.
- Refer to <https://www.guardsmanaustralia.com> for further details.

Cleaning Guide

Washing Instructions

- Ensure the zippers are done up before placing the slip covers in the washing machine
 - If the covers are too bulky for your washing machine, take them to your local laundromat for professional washing.
 - Professional dry cleaning is possible but some colour variation may occur if the cushions are cleaned separately from the main covers.
 - Wash below 30 degrees. Do not use a washing agent that contains optic bleach. We recommend Earth Choice 3X Ultra Concentrate Laundry Liquid, Eco Store Laundry Powder or Omo Expert Mixed Colours & Blacks Liquid.
 - Wash separately.
 - Do not squeeze or wring by hand.
 - Do not tumble dry.
 - Air dry in the shade.
 - Place the covers on the sofa frame when they are still slightly moist to minimise shrinkage and allow to dry completely before use.
-

Spot Cleaning

- Treat spills and stains as soon as possible.
- Test on hidden area to ensure fabric and colour are not removed.
- Gently scrape any soils or mop any liquids from the surface of the fabric.
- Use of soap or detergent with water should be approached with caution since overzealous rinsing to remove soap residue may result in over-wetting, water marking and possible wetting of substructure (this may create other stains or damage products).

For Non-Oil-Based Stains: Use warm water and non-toilet soaps which do not contain optical brighteners such as Velvet soap, Lux Flakes and Softly. Mix a small amount of soap and warm water solution and apply to the stain, rubbing gently. Blot dry with a clean white cloth. Apply cool water - preferably filtered or distilled - and blot dry again. Working from the outside of the stain with a hairdryer, dry quickly to prevent rings from forming. It is generally preferable to clean whole panels of fabric in this way rather than trying to spot clean specific areas.

For Oil-Based Stains: Following the same basic guidelines as above, apply a proprietary brand solvent based cleaner and try to clean generally in panels rather than spot cleaning specific areas.

User Recommendation

We hope you enjoy your new furniture. Correct maintenance will increase its longevity and keep it looking in tip-top condition for longer.

Follow these simple tips.

1. Furniture should be assembled according to our Assembly Guides.
 2. Store furniture on robust flooring in dry, well-ventilated rooms.
 3. Plump cushions with your hands to restore their shape after transportation or long periods of sitting.
 4. Keep furniture at least 30 cm away from radiators, air-conditioners and extreme temperatures.
 5. Protect your furniture from direct sunlight which can discolour fabric.
 6. We recommend dispersing weight evenly across the seat rather than repeatedly sitting in the same position.
 7. Rotate cushions regularly.
 8. Don't jump on or apply sudden force to the furniture as it may damage the frame or suspension.
 9. When repositioning the furniture, lift it - DO NOT drag it.
 10. Do not sit on the armrests as it can cause deformities or rupture the seams.
 11. Your pet's claws and teeth can damage furniture.
 12. Avoid using cleaning products containing harsh chemicals or oil dissolving solvents.
 13. Vacuum crevices of furniture on a low suction when needed.
-

Important points

1. Moisture

Our products are made using wood and other materials that can be sensitive to moisture. We recommend keeping furniture in an environment with 45-60% relative moisture and at 10-25°C.

2. Sunlight

After time the fabric colour will change slightly, which is a natural effect. To reduce this process, keep furniture out of direct sunlight.

3. Wear and Tear

Using furniture for a long time will result in slight material changes.

4. Pilling

Through regular use, the surface of natural fibre fabric can twist and form tiny balls – this is known as pilling. It is an inherent feature of this particular type of fabric and can be caused by environmental factors such as humidity or friction between two fabrics. It can be easily removed with a depiller and should disappear after 3-4 applications.

5. Storage

Ensure furniture stands on an even surface. This ensures stability and will prevent creaking or damage to the piece.

6. Felt Pads

We recommend attaching felt pads to the bottom of furniture legs. This prevents squeaking and protects your floor from scratches.

7. Fabric Variation

There may be slight variations between fabrics. The dyeing process means there is not an absolute guarantee that your sofa fabric will perfectly match the sample fabric.

8. Clothing and Accessories

Jeans and other dark clothing may leave stains or marks on furniture. Take extra care when wearing clothing that is new or not pre-washed. Also be careful wearing clothes with sharp decorative elements, as it may damage the fabric.

9. Softness

Furniture tends to soften after the first few months of use. This is a normal process. Parts of the furniture that are sat on more frequently will become softer than others.



www.1825interiors.com.au